

MACXLine® 4-1/16" Rigid Coaxial Transmission Line



Contents

Description	1
Components	1
Installation Tool Kit	2
Direction of Installation	2
Installing Full Sections (MACX450-1, 2, 3, 5, 10, 20, 42)	2
Installing Field Sections - Outer Conductor (MACX450-39, 41)	3
Installing Field Sections - Inner Conductor (MACX450-39)	4
Special Cut Procedure	4
Installing Field Sections - Inner Conductor (MACX450-41)	4
Attaching Elbow	5
Attaching Hangers and Braces	6
Attaching Wall Feed Thru Plate	7
Attaching Gas Barrier	8
Pressurization	8

Components

- 1 MACXLine components consist of straight line sections, elbows, and hangers.
- 1 Straight line sections are furnished in standard lengths of 20 ft, 19.75 ft and 19.5 ft. Special lengths can be provided for multiple channel applications. MACX450-1, 2, 3 are standard line sections with flanges welded on both ends. MACX450-39, 41 are field cut sections with one flange welded and one flange shipped loose for field installation. MACX450-5, 10, 20 are variable length specified by customer with flanges welded on both ends. MACX450-42 is a variable length section with flanges welded on both ends.
- 2 Each section includes inner conductor, outer conductor, intermediate insulators*, bullet-bellows*, flange insulator, flange hardware, silicone grease, and O-ring to seal flange.
- 2 Elbow inner conductor is shipped in two parts for easy assembly in the field. Flanges are swivel type to aid in alignment with straight sections. Each elbow is supplied with one bullet type inner connector for mating with straight section.
- 3 Hangers are provided for vertical spring support, horizontal spring support, lateral rigid support and vertical or horizontal section rigid support.

* Not supplied with MACX450-5.

Line and flange information:

Outer conductor diameter	4-1/16"
Flange diameter	6-3/16"
Bolt circle diameter	5-3/8"

Notice: Installation, maintenance, or removal of transmission line systems require qualified, experienced personnel. ERI installation instructions are written for such personnel. ERI transmission line should be inspected once a year by qualified personnel to verify proper maintenance and condition of equipment.

ERI disclaims any liability or responsibility for the results of improper or unsafe installation practices.

Description

Transmission line is designed to provide high power signal path between transmitter combiner and broadcast antenna. Corrugated bellows are provided at one end of the inner conductor to compensate for differential expansion between inner and outer conductor as the transmission line is heated during operation.

MACXLine installation requires at least three people and can begin at the antenna (top-down installation) or at the transmitter (bottom-up installation). Transmission line must be installed with the bellow-bullet end toward the antenna regardless of installation method. Outer conductor direction is identified by the red arrow label indicating "This end up", See Figure 1.

The entire transmission line is supported by hangers allowing the line to move for expansion and contraction during temperature change.

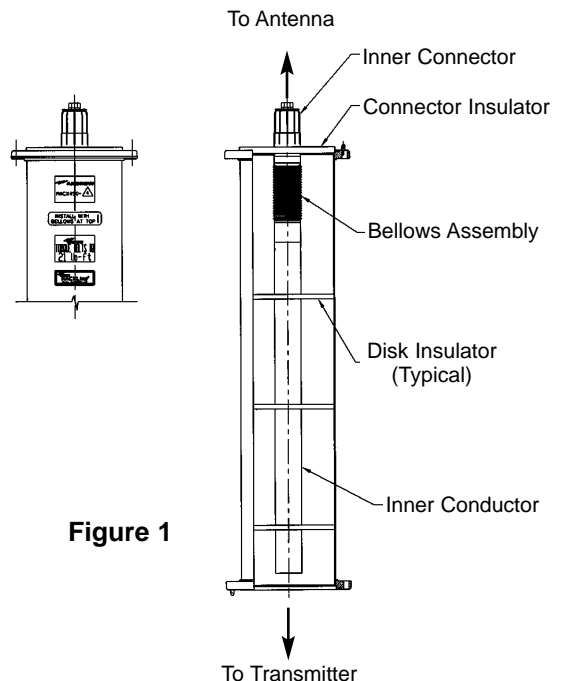

Figure 1

Installation Tool Kit

Tool Kit MACX450-TK is designed and furnished for proper assembly of MACXLine® transmission line. Tools include:

Tool box	5/16" Nut driver
Spanner wrenches (2)	Hose clamp
9/16" Deep socket, 3/8" Drive	3/8" Drive extension
9/16" Combination wrench	3/4" Deep socket, 3/8" Drive
Adjustable torque wrench	
Connector pliers	

Tool Kit MACX450-TK-2 is designed and furnished for proper assembly of MACXline field cut sections. Tools include:

Tool box
Field cut stub
Rosin core solder
Emery cloth

Additional Tools Required:

Hacksaw
Scribe
Tape measure
Acetylene torch and ignitor
Cleaning brush
Small brush for flux
Anti-seize lubricant
Cotton gloves
Caulk

Direction of Installation

Transmission line installation may begin at either end of the vertical run, Figure 2. Installation originating at the top (antenna end) of the vertical run requires at least one rigid hanger at the top (depending on length of vertical run). Proper positioning is required for the bottom miter elbow to allow for expansion and contraction of the rigid line over the anticipated operational temperature range.

Installation originating at the bottom (transmitter end) of the vertical run must use one or more rigid hanger supports to anchor transmission line. Continue to install transmission line using vertical or horizontal spring hangers using proper number and correct spacing.

Caution: Do not support more than one section of line on flange joint without using hangers. Ensure all horizontal runs of transmission line are protected from falling ice and debris to prevent possible damage. Rigid hangers used at the bottom of vertical runs for support during installation must be removed after installing top rigid hangers to prevent serious damage to antenna and/or transmission line.

Installing Full Sections

(MACX450-1, 2, 3, 5, 10, 20, 42)

- 1 Remove protective cover from line section flange.
- 2 Apply thin coating of silicone grease to O-ring and secure in flange groove. Use care to insure O-ring and flange groove are free of dirt before installing O-ring in groove.

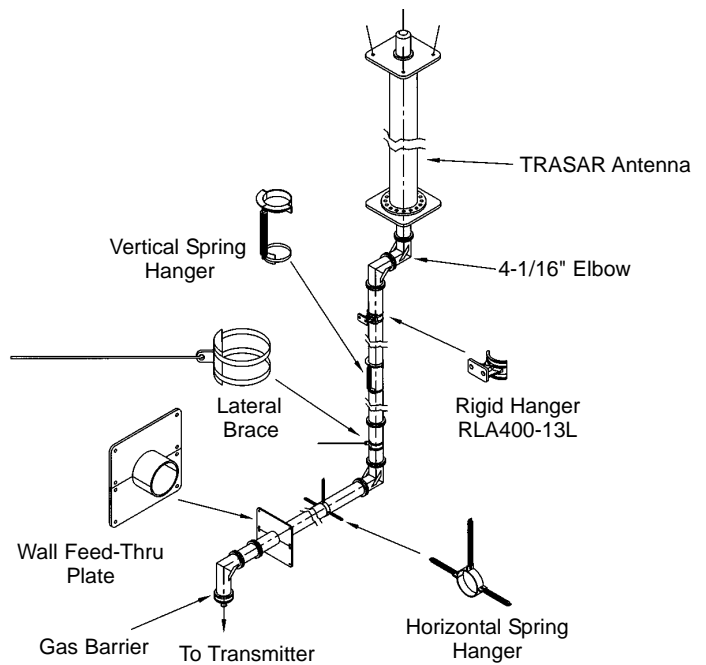

Figure 2

- 3 Remove excess silicone grease from flange contact surface to insure good electrical contact and pressure seal.
- 4 Align inner connector bullet with inner conductor from previously installed section, combiner or antenna. Mate bullet with inner conductor and keep aligned, Figure 3. Align flange pin with corresponding flange alignment hole and mate flanges. Verify flange insulator is properly seated in appropriate flange groove. Firmly push flanges together while checking that O-ring remains in correct position.

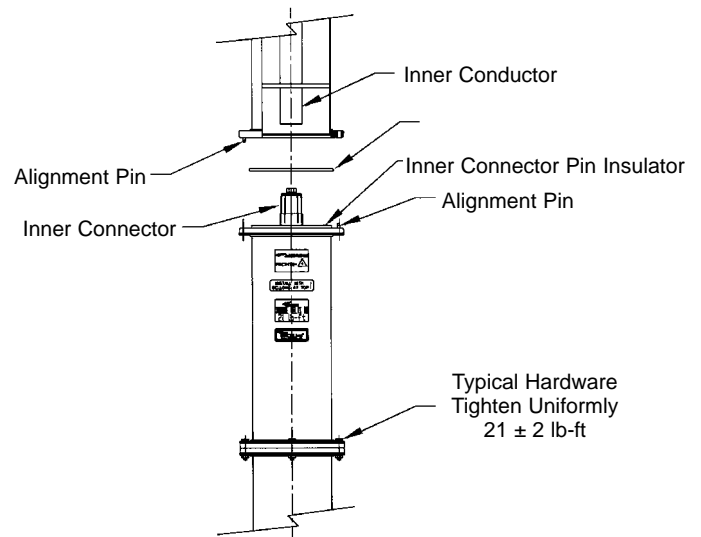

Figure 3

5 Install all flange hardware and alternately snug hardware at 180 degree locations, Figure 4, while maintaining a uniform gap between flanges. Perform final torque sequence in a similar pattern as above to a torque value of 21 lb-ft. When properly installed, a small uniform gap should be visible around flange circumference.

Note: Use anti-seize compound on all stainless steel hardware to prevent galling. If hardware becomes galled during tightening procedure, remove damaged hardware and install replacement hardware to insure proper electrical contact between flange surfaces.

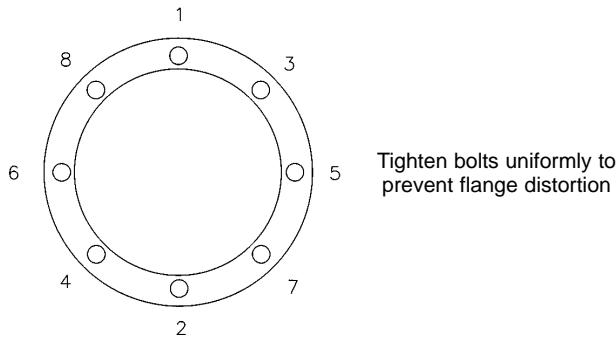

Figure 4

Installing Field Sections— Outer Conductor

(MACX450-39, 41)

Field sections are used for field trimming to nonstandard section lengths. Full section kits are supplied with inner and outer conductor, attaching hardware, one fixed flange attached and one solder flange for attachment in field.

1 Remove inner conductor assembly from outer conductor. Use extreme care to prevent distorting, denting or bending inner conductor and bellows section.

Note: MACX450-41 does not have bellows assembly due to length limitations.

2 Determine flange-to-flange transmission line length and deduct 3/8" to get outer conductor cut length.

3 Wrap piece of straight edged paper around outside of outer conductor as cutting guide. Scribe line along paper edge all the way around outer conductor, Figure 5.

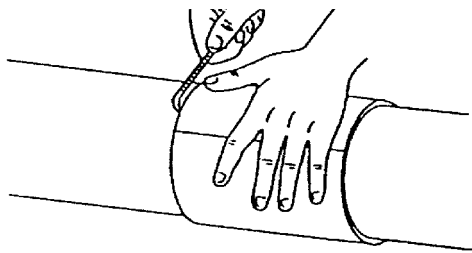

Figure 5

4 Carefully cut outer conductor with hacksaw. Make sure cut is square or flange will not seat properly on outer conductor, Figure 6. A band clamp can be used as an aid in making a square cut.

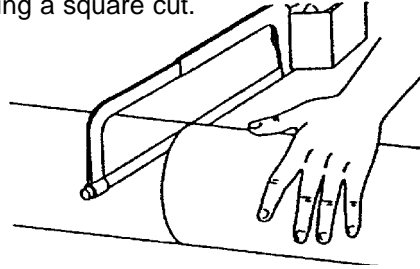

Figure 6

5 Remove burrs with a file and clean outer conductor end until bright. Do not use emery cloth or steel wool. Remove any debris from interior of outer conductor, Figure 7.

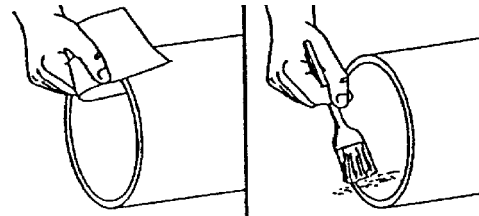

Figure 7

6 Apply silver solder flux to solder groove within flange and insert silver solder ring into groove, Figure 8.

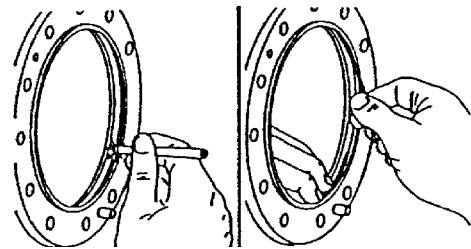

Figure 8

7 Apply silver solder flux to outer conductor outer edge and seat flange onto outer conductor, Figure 9.

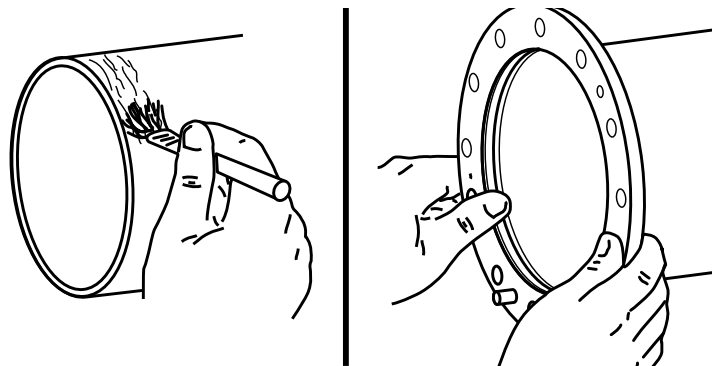

Figure 9

8 Heat joint to a temperature of 1200F (630C) with torch using gas and air with torch tip 2" to 3" from joint. Move torch evenly around joint so solder flows uniformly. When solder flows onto the outer surface of conductor and flange remove heat, Figure 10. Remove excess flux from assembly with hot water, then clean assembly with garnet cloth.

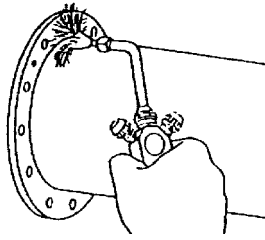

Figure 10

Installing Field Sections—Inner Conductor

(MACX450-39)

1 Determine required flange-to-flange outer conductor length, Figure 11.

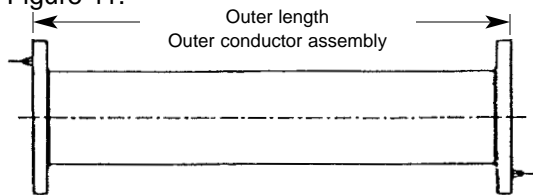

Figure 11

2 Subtract 1-9/32" from outer conductor length to obtain inner conductor length, Figure 12.

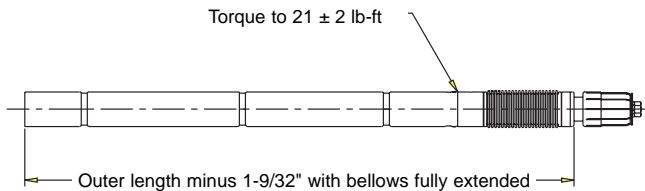

Figure 12

3 Remove inner conductor assembly from outer conductor. Remove intermediate and flange insulators for an accurate measurement. Be careful not to damage bellows during handling.

4 Use tape measure to mark inner conductor at required length making sure bellows is in relaxed position (fully extended) prior to marking.

Note: If mark falls within the "Do Not Cut" area, refer to the Special Cut Procedure, below, before proceeding to next step.

5 Wrap piece of straight edged paper around outside of inner conductor as cutting guide. Scribe line along paper edge all the way around inner conductor. Cut inner conductor at marked position using miter box and hacksaw. Remove burrs from inside and outside of conductor. Remove chips from inside of inner conductor.

6 Reinstall intermediate and flange insulators.

7 Carefully insert trimmed inner conductor into outer conductor with bellows toward antenna end of outer conductor. Push inner conductor back into outer conductor to fully seat flange insulator.

Special Cut Procedure

a. Remove inner conductor tube from bellows assembly using spanner wrench and adjustable connector pliers.

b. With inner conductor tube removed, measure and mark 24-1/2" from brass plug, Figure 13.

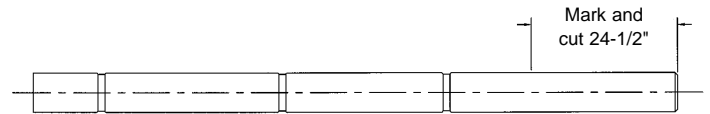

Figure 13

c. Cut inner conductor at marked position using miter box and hacksaw. Remove burrs from inside and outside of conductor, Figure 14.

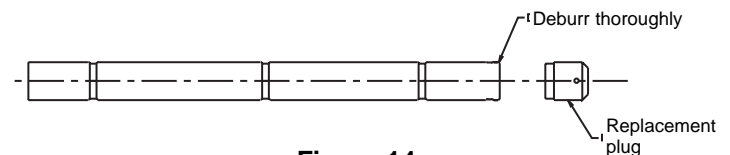

Figure 14

d. Install copper replacement plug into inner conductor and solder all around. Make sure no gaps or voids are visible between mating copper surfaces, Figure 15.

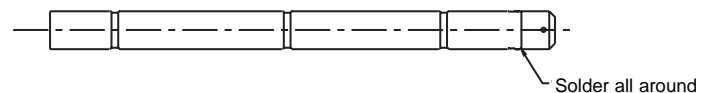

Figure 15

e. Reinstall modified inner conductor in bellows and torque connection to 21 ± 2 lb-ft.

f. Continue with step 4 in the section "Installing Field Sections - Inner Conductor", below.

Installing Field Sections—Inner Conductor

(MACX450-41)

1 Determine required flange-to-flange outer conductor length, Figure 11.

2 Subtract 2-1/2" from outer conductor length to obtain inner conductor length.

3 Remove inner conductor assembly from outer conductor. Use tape measure to mark inner conductor at required length, Figure 16.

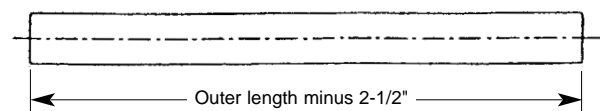

Figure 16

4 Wrap piece of straight edged paper around outside of inner conductor as cutting guide. Scribe line along paper edge all the way around inner conductor. Cut inner conductor at marked position using miter box and hacksaw. Remove burrs from inside and outside of conductor. Remove chips from inside of inner conductor.

5 Insert captivated inner connector into inner conductor and seat fully. Tighten inner connector bolt without bulging inner conductor, Figure 17.

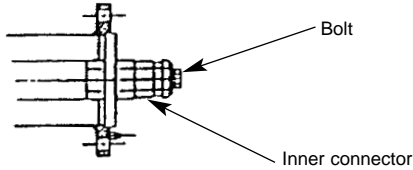

Figure 17

6 Carefully insert trimmed inner conductor into outer conductor and push inner conductor back into outer conductor to fully seat flange insulator.

Attaching Elbow

Inner Connector Installation

Refer to Figure 18. Fully insert the inner connector into one end of the the inner conductor as shown. Seat the inner connector insulator in the flange insulator groove. When properly seated, only half of the insulator remains exposed. Ensure the inner conductor at the opposite end is centered within the elbow. Visually check the gap between the inner conductor and the shoulder of the bullet. The gap should be less than 1/16". Tighten the inner connector bolt without bulging the inner conductor.

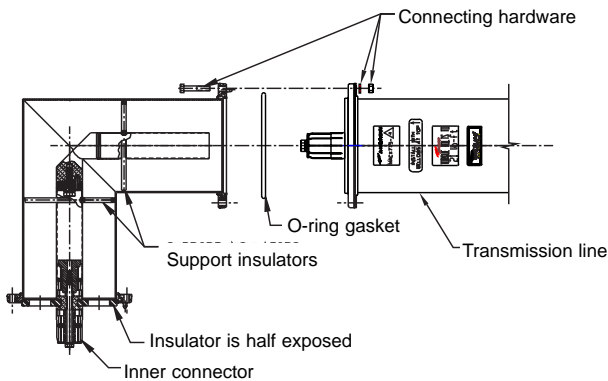

Figure 18

O-Ring Installation

Seat the O-ring gasket in the flange gasket groove on one of the elbow flanges. Be sure both the gasket and groove are clean. Any foreign matter may prevent the assembly from being pressure tight. A thin coating of silicone grease on the gasket will help to hold the gasket in place during assembly. Electrical contact surface must be free of silicone grease.

Elbow Installation

Join the elbow to the transmission line by engaging the inner connector (extending from the elbow) with the trans-

mission line inner conductor. Push the assembly together making certain the gasket remains in place and the inner connector insulator seats properly in the flanges. Rotate the swivel flange so the alignment pins are opposite the alignment holes, then push the flanges together.

Add the connecting hardware and bolt the flanges together, tightening the bolts finger tight. Alternately snug the hardware at 180° intervals while maintaining a uniform gap between the flanges. Perform the final torquing sequence in a circular pattern according to the torque specification table below and Figure 4. The gap between the flanges must be uniform. Do not overtighten.

Repeat the above steps for connecting transmission line to the other end of the elbow using the procedures and precautions mentioned.

Attaching Hangers and Braces

Rigid Hangers

The transmission line is anchored with rigid hangers near the top of the tower. This prevents any movement of the vertical line, due to temperature changes, from being transferred to the antenna. Such movement can cause stress damage.

A Type RLA 400-13 rigid hanger attached to the top straight section of transmission line on a tower anchors 1000 ft (305 m) of vertical run. If required, a second anchor

Hardware Torque Specifications

Hardware Size	Torque Value
3/8" (10 mm)	21 lb-ft (28 N-m)
1/2" (13 mm)	46 lb-ft (62 N-m)
5/8" (10 mm)	76 lb-ft (103 N-m)

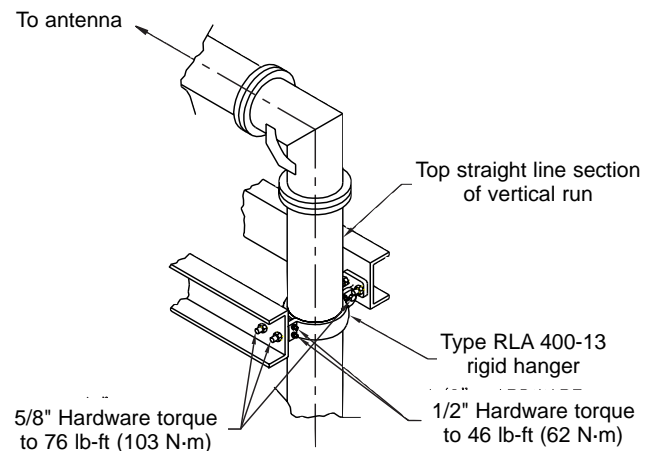
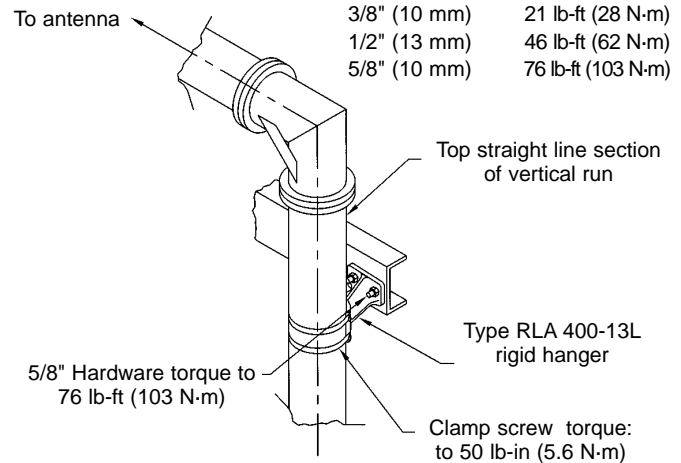

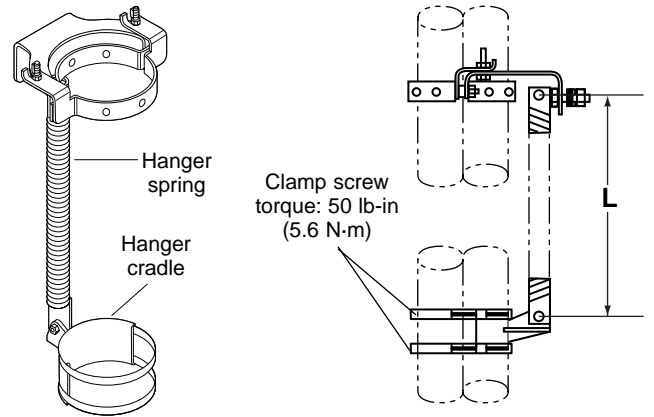
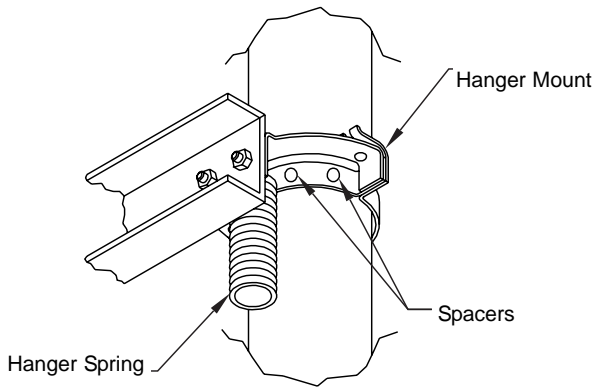

attached about 10 ft (3 m) below the first hanger will anchor an additional 1000 ft (350 m) or less of vertical run.

A Type RLA 400-13L rigid hanger attached to the top straight section of transmission line on a tower anchors 500 ft (152 m) of vertical run. If required, a second anchor attached about 10 ft (3 m) below the first hanger will anchor an additional 500 ft (150 m) or less of vertical run.

Use 5/8" hardware (supplied) to attach the hanger and tighten it to 76 lb-ft (103 N·m).

Caution: If there are no mounting holes in the tower member, contact the tower manufacturer for applicable safety regulations regarding the drilling of any holes in tower members.

Notice: Rigid hangers used at the bottom portion of the vertical run for increased support during installation must be removed after installation of top rigid hanger(s) to prevent serious damage to antenna and/or transmission line.

The horizontal run of the line is supported through the outside wall of the transmitter equipment building by a Wall Feed Thru.

Vertical Spring Hangers

The vertical run of transmission line is attached to the tower every 10 ft (3 m) with vertical spring hangers. These hangers accommodate expansion and contraction of the line with temperature changes. Hanger dimension L is adjusted at the time of installation according to the temperature as given in the table, below.

Use 5/8" hardware (supplied) to attach the hanger and tighten it to 76 lb-ft (103 N·m)

Caution: If there are no mounting holes in the tower member, contact the tower manufacturer for applicable safety regulations regarding the drilling of any holes in

Vertical Spring Hanger Spring Settings - L, in (mm)

Line Length ft (m)	Ambient Temperature, °F (°C)				
	0 to 20 (-18 to -7)	20 to 40 (-7 to 4)	40 to 60 (4 to 16)	60 to 80 (16 to 27)	80 to 100 (27 to 38)
0-200 (0-61)	22 (559)	22-1/16 (561)	22-1/8 (563)	22-1/4 (564)	22-5/16 (566)
200-400 (61-122)	21-3/4 (552)	21-15/16 (558)	22-1/8 (563)	22-3/8 (568)	22-9/16 (573)
400-600 (122-183)	21-1/2 (546)	21-13/16 (554)	22-1/8 (563)	22-1/2 (571)	22-13/16 (580)
600-800 (183-244)	21-3/16 (539)	21-11/16 (551)	22-1/8 (563)	22-5/8 (575)	23-1/16 (587)
800-1000 (244-305)	20-15/16 (532)	21-9/16 (547)	22-1/8 (563)	22-3/4 (578)	23-3/8 (593)
1000-1200 (305-366)	20-11/16 (525)	21-7/16 (544)	22-1/8 (563)	22-7/8 (581)	23-5/8 (600)
1200-1400 (366-427)	20-7/16 (518)	21-1/4 (540)	22-1/8 (563)	23 (585)	23-7/8 (607)
1400-1600 (427-488)	20-1/8 (511)	21-1/8 (537)	22-1/8 (563)	23-3/16 (588)	24-3/16 (614)
1600-1800 (488-549)	19-7/8 (505)	21 (534)	22-1/8 (563)	23-5/16 (592)	24-7/16 (621)
1800-2000 (549-610)	19-5/8 (498)	20-7/8 (530)	22-1/8 (563)	23-7/16 (595)	24-11/16 (628)

tower members.

After all spring hangers have been properly installed, set springs in accordance with Spring Settings table, below, and tighten clamps. The Table gives the spring setting based on both the line length from the rigid hanger at the top of the transmission line and on the air temperature, when the springs are set. To insure uniform settings, a setting guide may be made from a suitable material cut to the lengths specified in the Table.

Note: To avoid large variations in tension, all spring hangers should be set within hours of each other.

Lateral Brace

A lateral brace is required near the bottom of the vertical run of transmission line. The brace restricts lateral motion but allows horizontal and vertical movement of the line.

Loosely attach the band clamps and hanger cradle to the vertical straight section of the line above the miter elbow. Next, loosely attach the 3/8" eyebolt to a tower leg. Then, adjust the brace assembly for the least strain. Finally, tighten the clamp screws and eyebolt nuts.

Caution: If there is no eyebolt mounting hole, contact the tower manufacturer for applicable safety regulations regarding the drilling of any holes in tower members.

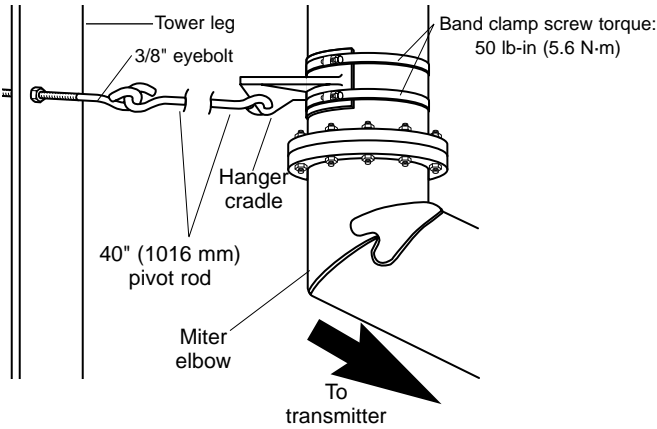

Suspension Spring Hangers

These hangers are designed for support of the horizontal run of transmission line. The hangers are attached to the ice shield structure or similar support structure at intervals of 10 ft (30 m) with 3/8" eyebolts. The hanger springs and pivot points (bolt and ball washer) accommodate the expansion and contraction of the vertical and horizontal runs with temperature changes.

Assemble the clamp segments around the transmission line and attach the hanger eyebolts to the support structure. Then, adjust the assembly to the position of least strain. Apply equal tensioning to the right and left springs by adjusting the 3/8" hardware evenly.

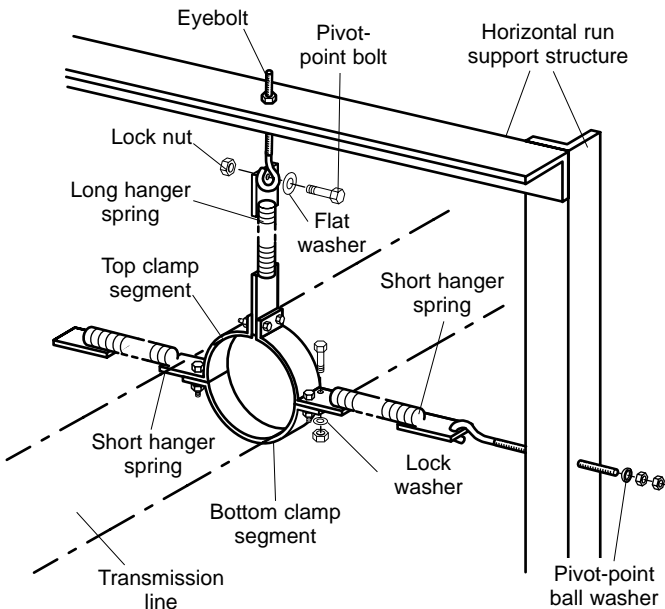

Attaching Wall Feed Thru Plate

1 This plate accommodates passage of a section of rigid transmission line through the metal or concrete wall or roof of the transmitter equipment building. The two-piece plate provides for proper weather sealing of the line to the building. Mounting holes are sized for 3/8" bolt hardware (not supplied).

The horizontal transmission line is first suspended within the wall or roof opening and securely fastened to the wall or roof with a rigid hanger (see Rigid Hangers). This prevents any movement of the vertical and horizontal runs due to temperature changes.

2 Hold the feed-thru plate halves together on the transmission line and against the mounting surface so that the line is centered in the tube. Then, mark all mounting hole positions for drilling.

3 Apply butyl tape (not supplied) around the area of transmission line to be covered by the tube of the feed-thru plate. This is to fill the gap between the line and the tube.

4 Apply caulk to the rear surface near the edge of the feed-thru plate halves.

5 Position both halves of the feed-thru plate around the transmission line and attach the plate to the wall or roof with 3/8" bolts.

6 Apply caulk to the bolt heads and around the outer edges of the plate.

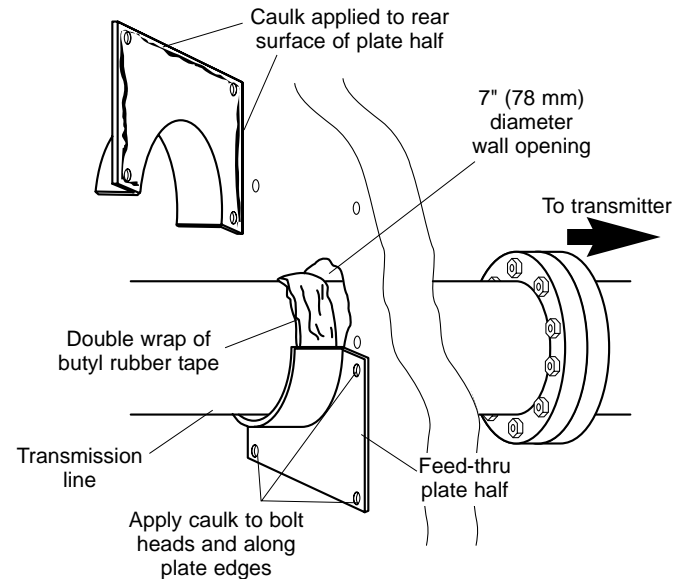

Attaching the Gas Barrier

A gas barrier is used to isolate the transmission line so that it can be pressurized with a source of dry air or other gas. Pressurization is needed in air-dielectric transmission lines because temperature variations cause moisture from outside air to enter the line, condense and seriously impair efficiency. Two ports on either side of the gas barrier insulator provide for separating pressurization sources; for example, placing a barrier between the transmission line and a radome-enclosed antenna allows for separate pressurization. This is useful in isolating a problem in one of these components when troubleshooting the system. If no gas barrier is installed at the top of the transmission line, both the line and the antenna can be pressurized from one source. If the antenna is not enclosed by a radome, the gas barrier is used to seal off the top end of the transmission line for pressurization.

A gas barrier is installed at the bottom end to the transmission line where the line is connected to a pressurization network within the transmitter equipment building. The gas tubing from either a dehydrator or other gas pressure source is connected to one of the gas barrier ports with a 1/8" NPT connector.

The transmission line must be purged of any moist air that has entered during installation. Purging is done by connecting the pressurization unit to a gas port at one end of the line and opening a gas port at the other end. The pressurization unit is allowed to run long enough for at least three air volume changes to take place. The open end of the line is then closed and the system is allowed to reach the pressure required. The pressure rating of the system should be the same as the lowest pressure rated component.

All pressurized transmission line connections should then be checked for leaks. Apply a commercial detector or a liquid detergent to the joints. Bubbling indicates leakage.

Pressurization

Maximum pressurization values are determined by lowest rated system component and should not be exceeded (typically 3-5 psi).

The transmission line is rated at 10 lbs/in² maximum. Consult applicable pressurization specifications on other system components (usually much lower) to determine maximum system pressurization limit (generally 3 psi with antenna, 1/2 psi with rectangular wave guide).

After installation is complete pressurize line and check flange connections for leaks. Use commercial leak detector or liquid detergent over joints and check for evidence of bubbles. Unbroken soap film over entire joint for several minutes indicates absence of noticeable leaks.

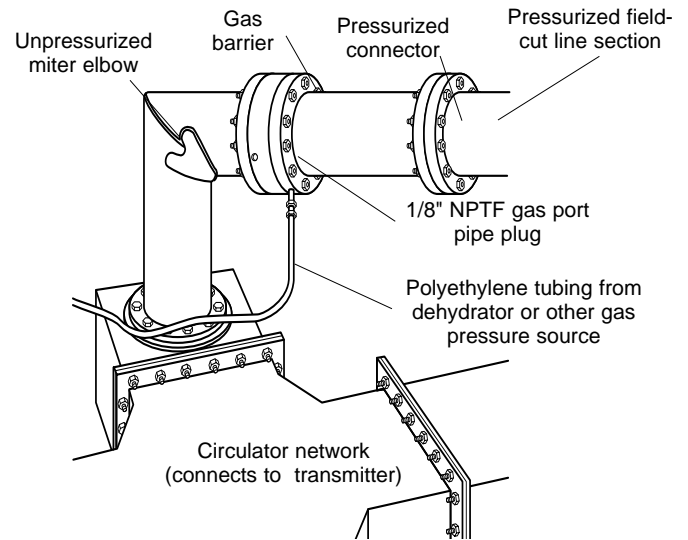

Transmission line must be pressurized at all times to prevent changes in ambient temperature from causing condensation to occur inside transmission line. This condensation can seriously impair transmission line performance. If moist air enters the system, it must be purged by removing gas port plug located on gas barrier or near antenna input flange.

Alternative method is to pressurize line and then let air escape at transmitter end of line. Repeat procedure several times allowing one hour each time for air to mix. After purging, replace gas port plug and pressurize line.

Line assemblies are not hermetically sealed and may exhibit low leakage rate. Line installations not using automatic gas supply must be periodically inspected. Dry air or nitrogen is normally used for pressurizing. Teflon tape is to be used on all gas ports or wherever pipe fittings are used on transmission line.



Electronics Research, Inc.

7777 Gardner Road, Chandler, Indiana 47610 USA

Tel: +1 (812) 825-6000 | Fax: +1 (812) 925-4030 | www.ERInc.com

Copyright © 2003 Electronics Research, Inc.

Printed in U.S.A. 20031222