

Male-to-Male Adapters

For Flanged Transmission Line Components

Types STD050-52, STD150-52, STD350-52, STD450-52, STD650-52, STD675-52, STD775-52, STD875-52, CA405, CA605, and CA705

Notice

The installation, maintenance, or removal of antenna systems requires qualified, experienced personnel. ERI installation instructions are written for such personnel. Antenna systems should be inspected once a year by qualified personnel to verify proper installation, maintenance, and condition of equipment. ERI disclaims any liability or responsibility for the results of improper installation practices.

Description

These adapters are designed to join two coaxial transmission line components having captivated inner connectors. Such components include flex sections, gas barriers, and coaxial cable connectors. Includes one flange hardware kit, but no inner connectors. Types CA405, CA605, and CA705 are also for male to male connections, but are specifically designed to connect Dielectric thin-walled inner conductor to ERI for the same nominal coaxial line size.

Adapter Installation Instructions

Read these instructions thoroughly before installation.

STEP 1:

(A) Remove and properly discard both protective end covers from the adapter's flanges. Be careful not to damage the inner conductor. Ensure that the adapter, O-ring gasket, and inner conductor are kept very clean.

(B) Engage the adapter inner conductor with the inner connector of the first line component as shown in Figure 1. Use a twisting motion to ensure complete engagement. For Types CA405, CA605, and CA705, ensure that the larger inner diameter (ie, thin-wall) side of the Adapter Inner Conductor in Figure 1 mates with Dielectric Corporation or RCA inner connector.

STEP 2:

Ensure both the O-ring gasket and flange groove of the first component are clean, as any foreign matter may prevent assembly from having a pressure tight seal. Apply a thin coating of silicone grease to the supplied gasket and to the flange groove, which will help to hold the gasket in place during assembly. Install the O-ring gasket by seating it into the groove. Remove any excess silicone grease from the flange contact surfaces to ensure proper electrical connection.

STEP 3:

(A) Place the adapter's outer conductor over the inner conductor and align its flange pins with the flange alignment holes of the first component. Join the mating sections, ensuring the O-ring gasket remains in place and the inner connector insulator seats properly in between mating flanges.

(B) Install and snug the mounting hardware at alternating 180 degree intervals while maintaining a uniform gap between the mating flanges. Perform the final tightening sequence according to Table 2. When properly installed, a small uniform gap should be noticed around the mating flange circumference.

STEP 4:

Ensure that the gasket and flange groove are clean on both mating flanges of remaining end. Apply a thin coating of silicone grease to both the O-ring and the flange groove of the adaptor. Install the O-ring gasket by seating it into the groove. Remove any excess silicone grease from the flange contact surfaces. Join the second component to the adapter by engaging the inner connector with the adapter's inner conductor. Repeat Step 3 (A and B) above for properly mating and securing the flanges of the second component with the adapter. Verify proper fit and that specified torque sequence from Table 2 and Figure 2 was applied.

Type No.	Line Size, in.	Impedance, Ohms	Length, in. (mm)	Hardware Size, in.
STD050-52	7/8	50	6 (152)	1/4
STD150-52	1-5/8	50	6 (152)	5/16
STD350-52	3-1/8	50	6 (152)	3/8
STD450-52	4-1/16	50	6 (152)	3/8
CA405	4-1/16	50	6 (152)	3/8
STD650-52	6-1/8	50	6 (152)	3/8
STD675-52	6-1/8	75	6 (152)	3/8
CA605	6-1/8	75	6 (152)	3/8
STD775-52	7-3/16	75	8 (203)	3/8
CA705	7-3/16	75	8 (203)	3/8
STD875-52	8-3/16	75	8 (203)	3/8

Table 1.

Line Size, in.	Torque Value, ft-lb (Nm)	Bolt Holes
7/8	7 (9)	3
1-5/8	12 (16)	4
3-1/8	21 (28)	6
4-1/16	21 (28)	8
6-1/8	21 (28)	12
7-3/16	21 (28)	14
8-3/16	21 (28)	18

Table 2.

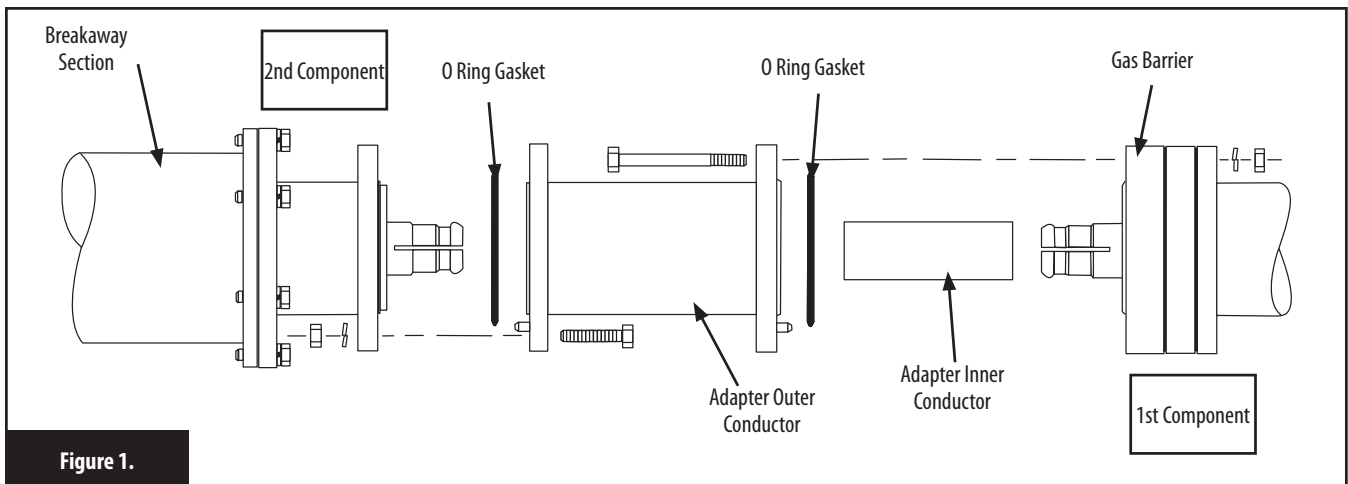

Figure 1.

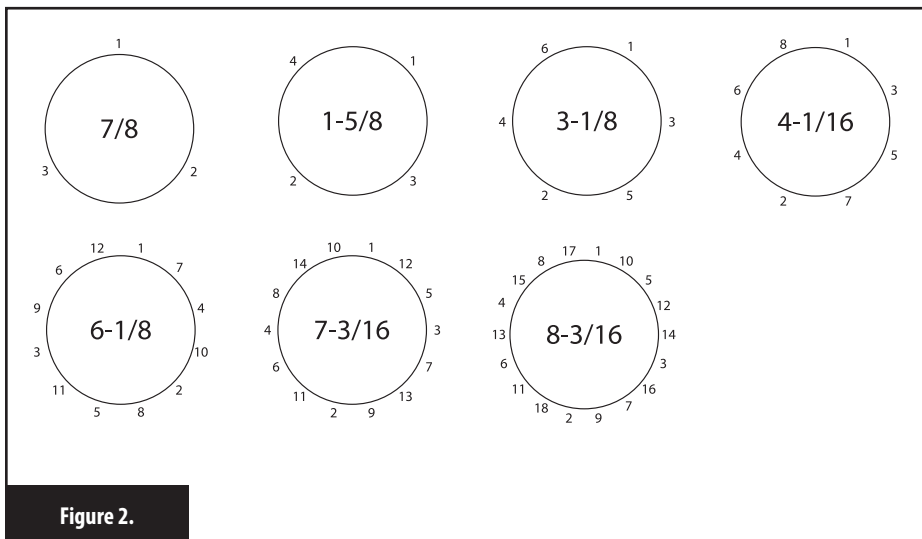

Figure 2.

For Technical Support call 877 ERI-LINE or +1 812 925-6000, or visit our website at www.eriinc.com

All designs, specifications, and availabilities of products and services presented in this publication are subject to change without notice. Publication II23005 Revision A (2009-03-13) Copyright © 2009 Electronics Research, Inc. Chandler, IN 47610 USA